

# Performance Analysis of Transmit Diversity in WCDMA System

Sheng-Jie Chen

BENQ Mobile System Inc.

No. 23 Li-Hsin Rd., Science Based Industrial Park, Hsin-Chu, Taiwan

E-Mail: sjchen@benqms.com

## Abstract

In this paper, we focus on the transmit diversity technologies in WCDMA system. There are two schemes: open loop and closed loop transmit diversity simulated in this paper. We simulated with various conditions to consider the applicability of transmit diversity in WCDMA system. The simulation conditions contain different feedback delays, feedback error rates, and velocities of fading channel. We also propose two kinds of channel estimation mechanisms into the simulation: one incur little delay but inaccuracy, the other incur one frame time delay but is much more accurate.

From the simulation results, we can know that in closed loop transmit diversity mode, the pilot symbol of DL DPCH seems not very helpful for channel estimation purpose. The CPICH will lead better performance for the system.

## 1 Introduction

In recent years, the spread spectrum communication systems are more and more important in digital cellular and personal communication networks. In particular, direct sequence code division multiple access (DS/CDMA) has been adopted in third generation cellular standard.

It is well known that to enhance the uplink capacity of the proposed 3G CDMA systems can be achieved by multi-antenna reception and multi-user detection (MUD). Techniques that increase the downlink capacity also have been mentioned in 3GPP specification. Transmit diversity provides an attractive skill for increasing the downlink capacity problem. A number of transmit diversity concepts have been proposed in recent years for WCDMA system. These can be classified as open loop transmit diversity and closed loop transmit diversity. The open loop transmit diversity employs a space time block coding based transmit diversity (STTD) and requires no knowledge

of the downlink channel of the transmitter. The closed loop mode has two sub-modes, which both utilize downlink channel measurements and feedback signaling in controlling the phases and/or gain transmit weights in the two transmit antennas.

The purpose of this paper is to analyze the transmit diversity capability gained by using these two kinds of transmit diversity mode used for WCDMA FDD system. We will summarize these two transmit diversity modes mentioned in 3GPP specification and the system model in Section 2. And the simulation results would be shown in Section 3. This paper is concluded in Section 4.

## 2 Transmit Diversity and System Model

In this section, we will review the transmit diversity methods mentioned in 3GPP specification. We also introduce the system model of the transmit diversity.

### 2.1 Open Loop Transmit Diversity

The open loop downlink transmit diversity employs a spaced time block coding based transmit diversity (STTD). The STTD encoding is optional in UTRAN. STTD support is mandatory at the UE. STTD encoding is applied on blocks of 4 consecutive channel bits. A block diagram of STTD encoder is shown in Figure 2.1. Channel coding, rate matching and interleaving are done as in the non-diversity mode.

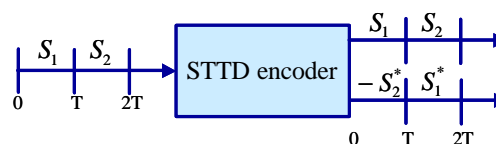

Figure 2.1 Block diagram of STTD encoder.

According to the received signal on path j by the transmitted signal at the time instant T is given by

$$r_j^1 = w_j^1 S_1 - w_j^2 S_2^* ,$$

where, the symbol  $w_j^i$  denotes the channel weight of the j-th multi-path of the i-th transmit antenna at the receiver.

Similarly, the received signal at time instant 2T is given by

$$r_j^2 = w_j^1 S_2 + w_j^2 S_1^* .$$

The mobile does the following linear processing to generate soft output for the symbol  $S_1$  and  $S_2$  for the j-th multi-path respectively:

$$r_j^1 w_j^{1*} + r_j^2 w_j^{2*} = (|w_j^1|^2 + |w_j^2|^2) S_1 ,$$

and

$$-r_j^1 w_j^2 + r_j^2 w_j^{1*} = (|w_j^1|^2 + |w_j^2|^2) S_2 .$$

The soft outputs from all the multi-paths can be combined to generate the net soft output for symbol  $S_1$  as

$$\sum_{j=1}^L r_j^1 w_j^{1*} + r_j^2 w_j^{2*}$$

where L is the total number of received paths. Similarly the net soft output for symbol  $S_2$  is generated as

$$\sum_{j=1}^L -r_j^1 w_j^2 + r_j^2 w_j^{1*}$$

In the equation listed above, the algorithm assumes that the channel weight in T and 2T are the same. This is reasonable, because the channel model is slow fading.

## 2.2 Closed Loop Transmit Diversity

In the 3GPP specification, we consider a CDMA system with two transmit antennas. In closed loop transmit diversity, the user equipment (UE) feeds back to the base station information that determining the

phase and power settings for transmit antennas.

The functional diagram of closed loop transmit diversity of a base station is illustrated in Fig. 2.2. The spread complex valued signal is fed to both antenna branches, and weighted with antenna specific weight factors  $w_1$  and  $w_2$ . The weight vectors are complex valued signals, in general. The weight vectors which corresponding phase/power adjustments are determined by the UE, and fed back to the base station using the D sub-field to the FBI field of uplink DPCCH. The target is to find a transmit weights that maximize the signal-to-noise ratio at the base station.

The computation of feedback information can be accomplished by solving for weight vector  $\bar{w}$ , which maximizes

$$P = \bar{w}^H H^H H \bar{w} \quad (1)$$

, where  $H = [h_1 \ h_2]$  and  $\bar{w} = [w_1 \ w_2]^T$ . The vectors  $h_1$  and  $h_2$  represent the channel impulse responses for the transmission antennas 1 and 2.

According to the (1), we can know that the optimum transmit weights is the eigenvector corresponding to the maximum eigenvalue of the channel autocorrelation matrix  $R = H^H H$ . In the WCDMA system, the UE uses the CPICH to separately estimates the channel form each antenna to get the estimated channel impulse responses  $\hat{h}_1$  and  $\hat{h}_2$ , where  $\hat{h}_1$  and  $\hat{h}_2$  are the estimation of  $h_1$  and  $h_2$  respectively. Thus, we can obtain  $\hat{R}$ , estimation of R, from the estimated channel impulse.

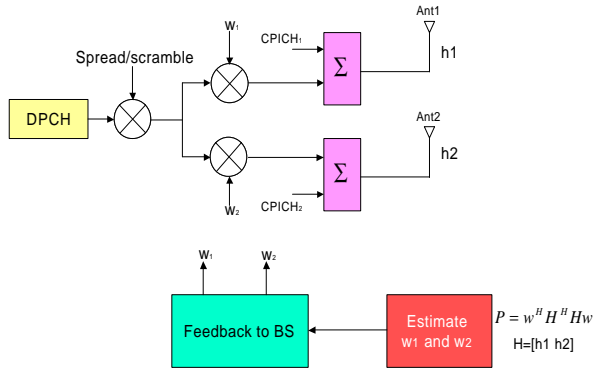

Figure 2.2 The general Downlink system support CLTD for DPCH transmission.

### 2.3 System Model

We consider a WCDMA system with two transmit antennas at downlink transmitter. The built downlink system follows the specification of Table 3.1 to simulate the transmit diversity mode. These transmit diversity schemes would follow the definition of 3GPP specification. Besides, we also simulate with various situations, like with different feedback delays, feedback error rates, the fading channels and etc. We would record the simulation results to compare with each simulation case.

The particular transmit power of Dedicated Physical Channel (DPCH) is defined as  $DPCH\_E_c$ . The total transmit power is defines as  $I_{or}$ , which is the summation of the total transmit signals. The maximum power density of the base station,  $I_{or}$ , is normalized to unity. We would allocate the power of mobile to be a fraction of the normalized power denote as  $DPCH\_E_c / I_{or}$ . Table 2.2 lists the power setting of each downlink channel in the simulation.

In closed loop transmit diversity mode, we need estimate the channel impulses to determine the

feedback weights to adjust DPCH channel. Here we propose two kinds of channel estimation mechanisms to determine the feedback weights. One estimates the channel impulse fast but inaccuracy, labeled as CE1. The function of CE1 is such called simple average, will incur 1 or 2 slots delay. The other one estimates the channel impulse accurately, labeled as CE2. Because of including filter in CE2, the latency of CE2 equals one frame nearly. We use these two channel estimation modes to determine the feedback weights to check the system performance. The close loop transmit diversity sub-mode used in the following simulation is mode 1, whose detailed specification are described in [8].

|                   |  |
|-------------------|--|
| Carrier frequency | 2140 MHz   |
| chip rate         | 3.84 MHz   |
| data rate         | 12.2 kbps  |
| channel           | 2 path Rayleigh; relative delay:0,976ns; average power: 0,-10 dB |
| modulation        | QPSK   |
| Codes             | scrambling code, spreading code                                  |
| encoding          | rate 1/3 convolutional code                                      |
| feedback delay    | 1 slots  |
| feedback error    | 4 (%)  |
| Update rate       | 1500 Hz  |

Table 2.1 Simulation Parameters.

| Physical Channel                         | Power   |
|--|---|
| P-CPICH (antenna 1)                      | P-CPICH_Ec1/lor = -13 dB  |
| P-CPICH (antenna 2)                      | P-CPICH_Ec2/lor = -13 dB  |
| SCH (antenna 1 / 2)                      | SCH_Ec/lor = -12 dB   |
| PICH (antenna 1)                         | PICH_Ec1/lor = -18 dB   |
| PICH (antenna 2)                         | PICH_Ec2/lor = -18 dB   |
| DPCH                                     | Test dependent power  |
| OCNS(Orthogonal Channel Noise Simulator) | Necessary power so that total transmit power spectral density of Node B (lor) adds to one |

Table 2.2 Power settings of downlink channels.

### 3 Simulation Results

According to the simulation parameters of Table 2.1, we take various parameters into account with the performance of these transmit diversity modes.

Figure 3.1 show that the performance of system with STTD and without STTD. We can see the performance of system with STTD will get over 4dB gain.

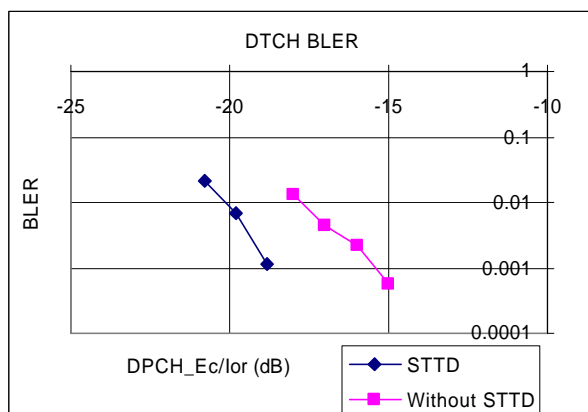

Figure 3.1 Results in 2-path Rayleigh channel 3km/h, with STTD and without STTD mode.

We also simulate with various speeds in close loop transmit diversity mode 1, shown in Figure 3.2.

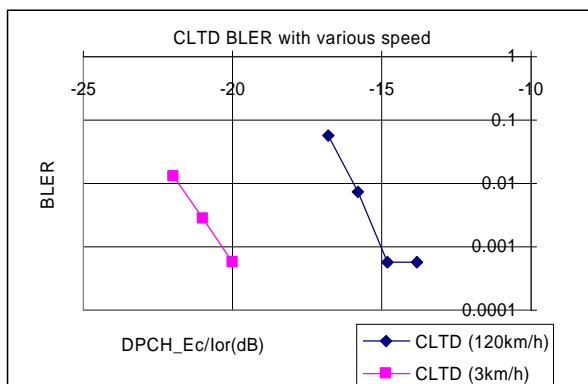

Figure 3.2 Results in Rayleigh channel with 3 km/h two paths and 120 km/h four paths in closed loop transmit diversity mode.

The feedback delay is also important in closed loop transmit diversity, we try to delay the feedback weights with 1 to 5 slots, shown in Figure 3.3. The performance is almost similar, this because the channel is a very slow fading channel. The feedback error is another issue in CLTD, the simulation results is shown in figure 3.4. The higher the feedback error rate is, the poorer the system performance is.

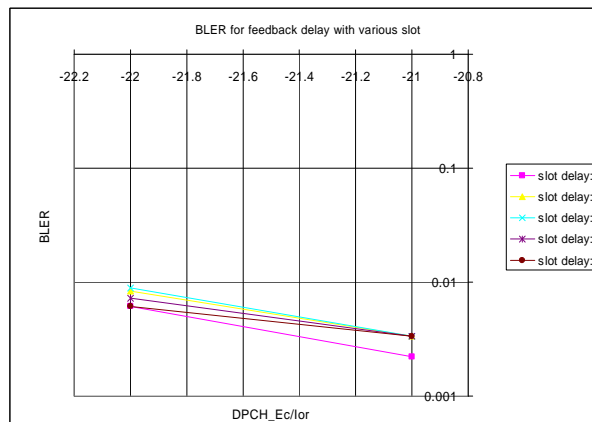

Figure 3.3 Results in Rayleigh channel 3 km/h, with various feedback delay n slots.

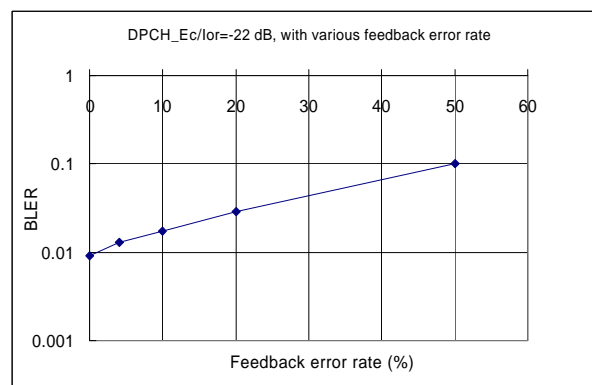

Figure 3.4 Results in Rayleigh channel 3 km/h, with various feedback error rate.

In closed loop transmit diversity, we simulate the system with the channel estimation mechanism we designed: CE1 and CE2. First, we try to simulate by using CE1 and CE2 to estimate the CPICH used to determine the feedback weights to affect the system performance. In Figure 3.5, we can see that

performance by using CE1 to determine feedback weights is better than using CE2. So we decide to use CE1 to estimate the CPICH to determine feedback weights.

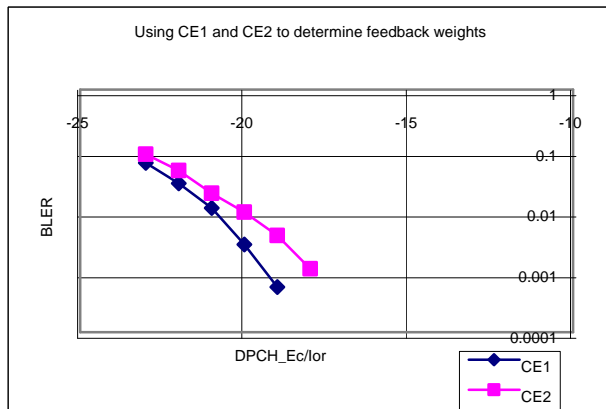

Figure 3.5 Results in Rayleigh channel with 3km/h two paths by using CE1 and CE2 to determine feedback weights.

There are two ways to estimate the channel, of course, one is CPICH, and the other one is pilot symbol of DPCH. In RAKE receiver, we need accurate channel estimation, so we choose CE2 to estimate the channel. We also run a simulation to determine CE2 estimate from CPICH or pilot symbols of DPCH for RAKE receiver. In Figure 3.6, we can clearly see the performance of channel estimation estimated from CPICH is better than estimated from pilot symbols of DPCH.

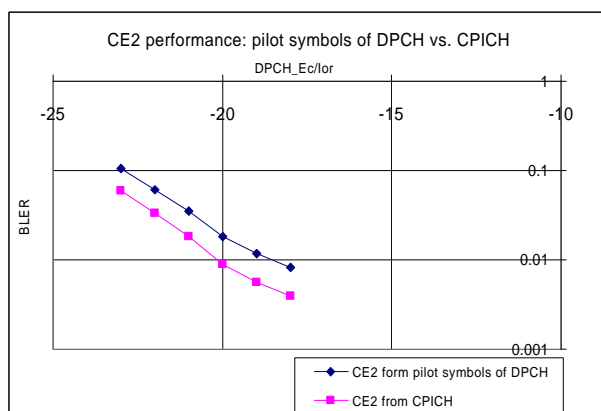

Figure 3.6 Results in Rayleigh channel with 3km/h

two paths, CE2 estimates from pilot symbols of DPCH and CPICH for RAKE used.

## 4 Conclusion

Two transmit diversity modes: open loop transmit diversity and closed loop transmit diversity were studied by simulation. We can check the simulation results to get: system with transmit diversity achieves better performance over 4 dB than system without transmit diversity in slow speed. The transmit diversity takes no advantage in high speed channel model. In the same way, we can verify this conclusion from feedback error rate. In high speed channel model, the increase of feedback error results in the performance degrades.

From the simulation results, we can observe that the CPICH for channel estimation would get better performance than the pilot symbols of DPCH. We can make a conclusion: the pilot symbols of DPCH is not necessary for downlink system, the pilot bits may be replaced by other useful information bits to make system performance more better.

## 5 Acknowledgement

The node B system is a joint work accomplished by all the team members in BMS Inc. The authors appreciated the great help from them.

## 6 References

- [1] Ari Hottinen and Risto Wichman, "Transmit diversity using filtered feedback weights in the FDD/WCDMA system", Nokia Research Center, IEEE, 2000.
- [2] Balaji Raghothaman, Giridhar Mandyam, R. Thomas Derryberry, "Performance of closed loop transmit diversity with feedback delay", Nokia Research Center, IEEE, 2000.
- [3] Jyri Hamalainen, Risto Wichman, "Closed-Loop Transmit Diversity for FDD WCDMA Systems", Nokia Research Center, IEEE, 2000.
- [4] Eko N. Onggosanusi, Alan Gatherer, Anand G. Dabak, Srinath Hosur, "Performance Analysis of Closed-Loop Transmit Diversity in the Presence of Feedback Delay", IEEE Transactions on communications, Vol. 49, No. 9, September 2001.
- [5] Jyri Hamalainen, Risto Wichman, "The Effect of

Feedback Delay to the closed-loop Transmit diversity in FDD WCDMA”, Nokia Research Center, IEEE, 2001.

- [6] Aradhana Narula, Michael J. Lopez, Mitchell D. Trott, and Gregory W. Wornell, “Efficient Use of Side Information in Multiple-Antenna Data Transmission over Fading Channel”, IEEE, 1998.
- [7] Shirish Nagaraj, Yih-Fang Huang, “Downlink Transmit diversity: Feedback Efficiency and Robustness”, IEEE, 2000.
- [8] 3GPP Technical Specification TS 25.214.
- [9] 3GPP Technical Specification TS 34.121.